

# VOLAT

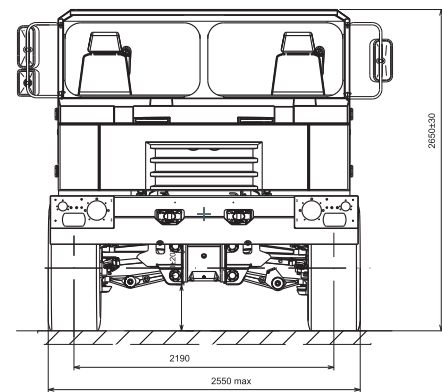

CARGO TRUCK  
MZKT - 5002

VEHICLES OVERCOMING ALL OBSTACLES

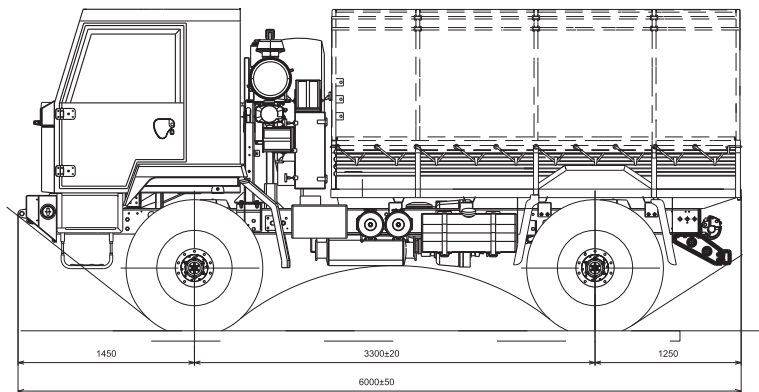

## SPECIFICATIONS

### PERFORMANCE DATA

Wheel drive	4x4
Max. speed, km/h	95
Gradeability, %	60
Angle of approach	40°
Angle of departure	32°
Ground clearance, mm	400
Climbing ability-vertical step, mm	350
Side slope, %	40
Turning radius (curb to curb), m	10
Crossing ability-fording depth, m	1,8
Trench width, m	1
Cruising range, km	1000
Operating temperature, °C	-40 - +50
Fuel tank capacity, l	2x130

### WEIGHT DATA

Curb vehicle weight, kg	6 400
Payload, kg	3 000
Gross vehicle weight, kg	9 400

### ENGINE

Type	YaMZ-53452
Number and location of cylinders	L4
Power	158 kW (215 h.p.)

### TRANSMISSION

Type	manual
	SAAZ-4334M3
Number of gears	5 forward, 1 reverse
Gear ratio	5.81-0.81

### TRANSFER CASE

Number of gears	2
Gear ratio	1:1; 1:1.878

### DRIVING AXLES

Central reduction gears with interaxle and cross-axle differentials locks, planetary wheel hub reduction

### AXLE SUSPENSION

Independent suspension, coil springs

### STEERING SYSTEM

Left hand drive, hydraulic power assisted

### BRAKE SYSTEM

Shoe brake on each wheel with pneumatic drive  
Dual-circuit system

### TYRES

110x400-533 or 12.00-20  
Central tyre inflation system (CTIS)

### FRAME

Longitudinal  
Equipped with front and rear towing units

### CAB

Metallic framework  
Equipped with heating system, storage for documents, tools, crew personal equipment

### ELECTRICAL EQUIPMENT

Nominal voltage, V

24

### PLATFORM

Tarp covered body

### OPTIONS

Portable electric self-recovery winch